

DEVILBISS

SB-E-2-790 ISS.05

CE  II 2 G X

OPERATION MANUAL

FLG-G5

Transtech Gravity Spraygun



E	1 – 7	F	9 – 15
D	16 – 22	NL	23 – 30



Operation Manual

FLG5 – Gravity Feed Spraygun

Important

Read and follow all instructions and Safety warnings before using this equipment

Description

The FLG5 Gravity Spraygun is fitted with a 1.4 or 1.8mm Nozzle for topcoat applications. Alternative 2.0mm Nozzle and Needles are available for primer use. The FLG5 Gravity Feed Spraygun is approved to ATEX regulations 94/9/EC, protection level;

II 2 G X

Suitable for use in Zones 1 and 2

Important: *These Sprayguns are suitable for use solvent based coating materials. The design uses EPA compliant atomising (Devilbiss Trans-Tech®) technology to reduce overspray and improve coating efficiency. Nozzles and Needles are manufactured in Stainless Steel. These guns are not designed for use with highly corrosive and/or abrasive materials and if used with such materials it must be expected that the need for cleaning and/or replacement of parts will be increased. If there is any doubt regarding the suitability of a specific material contact your local Distributor or ITW Finishing direct.*

Example:	Model Part Number FLG-G5-14	Nozzle Size 1.4 or 1.8
----------	--	---------------------------

SPECIFICATION	
Air supply connection –	Universal 1/4 BSP and NPS
Maximum static air inlet pressure –	P ₁ = 12 bar (175 psi)
Nominal gun inlet pressure with gun triggered –	2.4 bar (35 psi)
Maximum Service temperature –	40°C
Gun Weight –	640g
Airflow –	277 l/min (9.8 cfm)
Materials of Construction	
Gun body	- Aluminium
Nozzle	- Stainless steel
Needle	- Stainless Steel
Cup	- Acetal and Stainless Steel

ITW Finishing Systems and Products reserve the right to modify equipment specification without prior notice.



SAFETY WARNINGS



Fire and explosion

Solvents and coating materials can be highly flammable or combustible when sprayed. **ALWAYS refer to the coating material suppliers instructions and COSHH sheets before using this equipment.**



Users must comply with all local and national codes of practice and insurance company requirements governing ventilation, fire precautions, operation and house-keeping of working areas.



This equipment, as supplied, is NOT suitable for use with Halogenated Hydrocarbons.



Static Electricity can be generated by fluid and/or air passing through hoses, by the spraying process and by cleaning non-conductive parts with cloths. To prevent ignition sources from static discharges, earth continuity must be maintained to the spraygun and other metallic equipment used. It is essential to use conductive air and/or fluid hoses.



Personal Protective Equipment



Toxic vapours – When sprayed, certain materials may be poisonous, create irritation or be otherwise harmful to health.

*Always read all labels and safety data sheets for the material before spraying and follow any recommendations. **If In Doubt, Contact Your Material Supplier.***



The use of respiratory protective equipment is recommended at all times. The type of equipment must be compatible with the material being sprayed.

Always wear eye protection when spraying or cleaning the spraygun.



Gloves must be worn when spraying or cleaning the equipment.



Training – Personnel should be given adequate training in the safe use of spraying equipment.

Misuse

Never aim a spraygun at any part of the body.

Never exceed the max. recommended safe working pressure for the equipment

The fitting of non-recommended or non-original spares may create hazards.

Before cleaning or maintenance, all pressure must be isolated and relieved from the equipment.

The product should be cleaned using a gun washing machine. However, this equipment should not be left inside gun washing machines for prolonged periods of time.

Noise Levels

The A-weighted sound level of sprayguns may exceed 85 dB (A) depending on the set-up



being used. Details of actual noise levels are available on request. It is recommended that ear protection is worn at all times when spraying.

Operating

Spray Equipment using high pressures may be subject to recoil forces. Under certain circumstances, such forces could result in repetitive strain injury to the operator.

E

Ref. No	Part Number	Description	Qty
1	SGK-0023	Retaining ring	1
2	FLG-0001-5	Air cap	1
3	SGK-0012-14 SGK-0014-18 SGK-0012-20	Fluid Tip 1.4mm Fluid Tip 1.8mm Fluid Tip 2.0mm (available separately)	1
★ ● 4	-	Gasket	1
★ ● 5	-	Baffle	1
★ 6	-	Packing	1
7	-	Packing gland nut	1
8	-	Retaining ring	1
9	-	Spray pattern adjustment valve bushing	1
10	-	Spray pattern valve	1
★ 11	-	U-cup seal	2
★ 12	-	Air valve seat	1
★ 13	-	Air valve stem	1
★ 14	-	Air valve spring	1
15	-	Air valve bushing	1
16	SGK-0414 SGK-0418 SGK-0420	Fluid needle 1.4mm Fluid needle 1.8mm Fluid Needle 2.0mm (available separately)	1
17	-	Fluid needle spring	1
18	-	Fluid adjustment knob	1
19	-	Nipple	1
20	-	Retaining ring	1
21	-	Air adjusting valve head	1
22	-	Air adjusting valve assembly	1
23	-	Retaining ring	1
24	-	Trigger pin assembly	1
25	-	Trigger	1
26	-	Fluid nipple	1
28	KGP-5	Filter	1
29	GFC-402	Lid assembly	1
30	GFC-2-K5	Drip free vent lid kit of 5	1
31	GFC-501	Cup assembly	1
★ 32	-	Assembly tool	1

★	K-5040:	Seal, Baffle and gasket replacement kit, items 4, 5, 6, 11, 12, 13, 14 and 32
●	K-5030:	Baffle replacement kit, items 4 and 5.

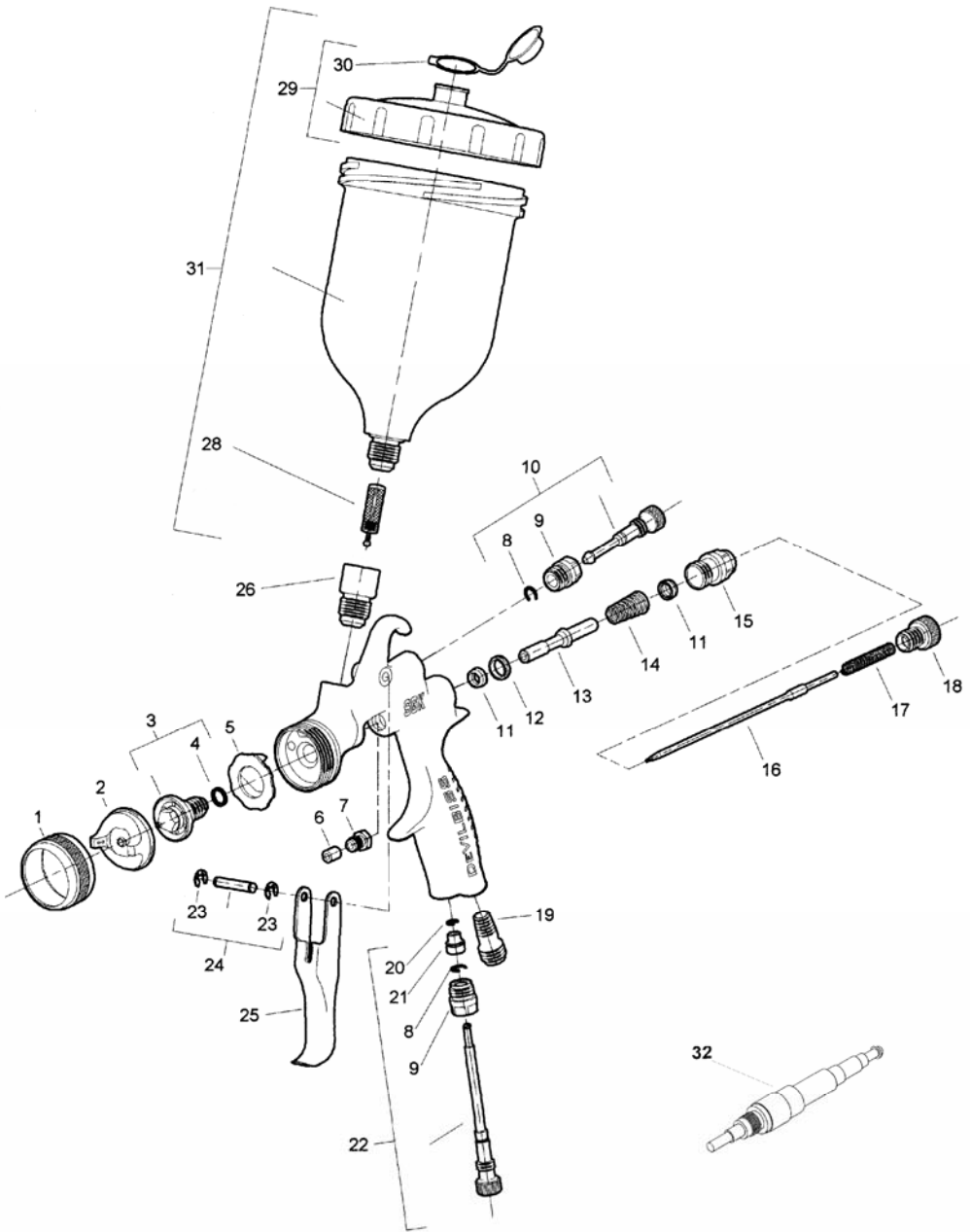

Installation

Important: To ensure that this equipment reaches you in first class condition, protective coatings have been use. **Flush the equipment through with a suitable solvent before use.**

1. Attach air hose to connector (19). Recommended hose size 8 mm bore. The hose must be conductive and

electrical bond from the spraygun to earth should be checked with an ohmeter. A resistance of less than $10^6\Omega$ is recommended.

2. Air supply should be filtered and regulated.

Operation

1. Mix coating material to manufacturers instructions
2. Turn needle adjusting screw (18) counter-clockwise until first thread shows
3. Turn pattern valve (10) counter-clockwise to fully open
4. Adjust inlet air pressure to give 2.4 bar (35 psi) at the gun inlet with the gun triggered. (*pressure gauge attachment shown under Accessories is recommended for this*)
5. Test spray. If the finish is too dry reduce airflow by reducing inlet pressure. If finish is too wet reduce fluid flow by turning needle screw (18) clockwise. If

atomisation is too coarse, increase inlet air pressure. If too fine reduce inlet pressure.

6. The pattern size can be reduced by adjusting valve (10)
7. Hold gun perpendicular to surface being sprayed. Arcing or tilting may result in uneven coating.
8. The recommended spray distance is 150-200 mm (6"-8").
9. Spray edges first. Overlap each stroke a minimum of 50%. Move gun at a constant speed.
10. Always turn off air supply and relieve pressure when gun is not in use.

Preventative Maintenance

1. Turn off air supply and relieve pressure in the airline, or if using QD system, disconnect from airline.
2. Empty coating material into a suitable container and clean the gun and cup, preferably in a gun wash machine.
3. **IMPORTANT– the cup must not be cleaned or rubbed with a dry cloth or paper. It is possible to generate a static charge, by rubbing, which if discharged to an earthed object could create an incendive spark and cause solvent vapours to ignite. Only use a dampened cloth or antistatic wipes if additional cleaning is required in a Hazardous**

area.

4. Remove air cap (2) and clean. If any of the holes in the cap are blocked with coating material only use the Cleaning Kit KK-4584 (see accessories) which has the correct tools for this or a toothpick to clean. Using any other tool could damage the cap and produce distorted spray patterns.
5. Ensure the tip of the nozzle is clean and free from damage. Build up of dried paint can distort the spray pattern.
6. Lubrication – Trigger stud (24), needle (16) and air valve spindle (13) should be oiled each day.

Replacement of Parts

Nozzle (3) and Needle (16) – Remove parts in the following order: 18, 17, 16, 1, 2 and 3. Check condition of Nozzle Seal (4) and replace if necessary. Replace any worn or damaged parts and re-assemble in reverse order. Recommended tightening torque for nozzle (3) 16-20 Nm (150-180 lbf in).

Packing – Remove parts 18, 17, 16. Unscrew Packing Nut (7). Remove packing (6). Fit new packing (6) and Nut (7). Re-assemble parts 16, 17, and 18 and tighten Packing Nut (7) with spanner sufficient to seal but to allow free movement of needle. Lubricate with gun oil.

Air Valve Seal Kit (K-5040)

1. Remove Adjusting Knob (18), Spring (17), and Needle (16).
2. Loosen Housing (15).
3. Remove Housing (15) and Airvalve Spring (14).
4. Remove Spindle (13).
5. Using Service Tool (32), engage groove behind the Valve Seat (12) and remove Valve Seat.
6. Push out the Front Airvalve Seal (11).
7. Turn the Gun upside down and let the Seal fall out.
8. Fit New Front Seal (11) to Service Tool.
9. Fit new Seal to Gunbody and press firmly to ensure Seal is engaged.
10. Fit New Valve Seat (12) to Service Tool and fit Valve Seat into Gunbody.

11. Remove Rear Airvalve Seal (11) from housing (15) with a hooked instrument.
12. Fit new Seal to Service Tool and Fit Seal to Housing (15).
13. Replace Spindle (13).
14. Replace Valve Spring (14), screw in Housing (15) and tighten.
15. Screw reverse end of Service tool into housing until fully engaged. Tighten by hand to seat the Valve Seat. Remove tool.
16. Fit Needle (16), Spring (17) and Knob (18).
17. Adjust Needle Packing (7) with Spanner sufficient to seal but to allow free movement of needle. Lubricate with gun oil.

Spreader valve (10) – Caution: always ensure that the valve is in the fully open position by turning screw fully counter-clockwise before fitting to body.

Air cap / Nozzle Selection

Refer to coating material manufacturers recommendations or ITW Finishing UK Website:

www.itweuropeanfinishing.com

Accessories

Cleaning Brush – order 4900-5-1-K3

Pressure gauge Attachment – order HAV-501

Digital Pressure Gauge – DGI-501-BAR

Lubricant – order GL-1-K10

Spraygun cleaning Kit – KK-4584

EC Declaration of Conformity

We: ITW Finishing UK, Ringwood Rd, Bournemouth, Dorset, BH11 9LH, UK, as the Authorised Representative of the manufacturer of the **Spraygun model FLG5**, declare, under our sole responsibility, that the equipment to which this document relates is in conformity with the following standards or other normative documents:

BS EN 292-1 PARTS 1 & 2: 1991, BS EN 1953: 1999; and thereby conform to the protection requirements of Council Directive **98/37/EC** relating to **Machinery Safety Directive**, and;

EN 13463-1:2001, council Directive **94/9/EC** relating to **Equipment and Protective Systems intended for use in Potentially Explosive Atmospheres protection level II 2 G X**.

This product also complies with the requirements of the EPA guidelines, PG6/34. Transfer efficiency certificates are available on request.



B. Holt, General Manager
1st January 2006

BINKS DVP 1:1 RATIO DIAPHRAGM PUMP PACKAGES



- Rapid delivery of up to 17 litres per minute (max)
- Even material flow at up to 60 cycles/minute
- Economic air consumption at pressures up to 7 bar (100 psi)
- Corrosion resistant models for ceramic/abrasive materials
- Functions as a material transfer or delivery pump
- Choice of pail, wall, tripod or cart mounted outfits
- ATEX/CE approved.

PRESSURE FEED TANKS & CUPS

- Sizes to suit all applications
- 10, 40 & 60 litre capacity tanks complete with nylon inner container for easy colour changes and cleaning
- Stainless steel and mild steel options
- Compatible with your standard gun and hose connections
- Remote pressure cups – aluminium and stainless steel options
- 2 litre capacity
- ATEX/CE approved.



ITW Industrial Finishing – Masters of Finishing Technology

www.itwifueuro.com